



Shenzhen Big Fish Sports Technology Co . , LTD.

CE EMC REPORT

Prepared For :	Shenzhen Big Fish Sports Technology Co . , LTD. 201-17 Jiangnan Building ,No.21, East Yongxiang Road, Ma' an tang Community, Bantian Street, Longgang District, Shenzhen, China.
Product Name:	Electric Bicycle
Model :	ENGINE X
Prepared By :	BST Testing (Shenzhen) Co.,Ltd. No.7, New Era Industrial Zone, Guantian, Bao'an District, Shenzhen, Guangdong, China.
Test Date:	Jun. 3, 2022–Jun. 9, 2022
Date of Report :	Jun. 9, 2022
Report No.:	BST22060821850301ER



1. TEST RESULTS SUMMARY	5
2. GENERAL INFORMATION	6
2.1. Report information	6
2.2. Measurement Uncertainty	6
3. PRODUCT DESCRIPTION	7
3.1. EUT Description	7
3.2. Block Diagram of EUT Configuration	7
3.3. Operating Condition of EUT	7
3.4. Test Conditions	7
3.5. Modifications	7
3.6. Abbreviations	8
3.7. Performance Criterion	8
4. TEST EQUIPMENT USED	10
4.1. For Conducted Emission Test	10
4.2. For Disturbance Power Test	10
4.3. For Harmonic / Flicker Test	10
4.5. For RF Strength Susceptibility Test	10
4.7. For Surge Test	11
4.9. For Magnetic Field Immunity Test	11
5. POWER LINE CONDUCTED EMISSION TEST	12
5.2. Test Standard	12
5.3. Power Line Conducted Emission Limit	12
5.4. EUT Configuration on Test	12
5.5. Operating Condition of EUT	13
5.6. Test Procedure	13
5.7. Test Result	13
6. DISTURBANCE POWER TEST	14
(EUT: Electric Bicycle)	14
6.2. Disturbance Power Limit	14
6.3. EUT Configuration on Test	14
6.4. Operating Condition of EUT	14
6.5. Test Procedure	15
6.6. Disturbance Power Test Result	15
7. HARMONIC CURRENT EMISSION TEST	16
7.1. Block Diagram of Test Setup	16
7.2. Test Standard and Limit	16
7.3. Test Procedure	17
7.4. Test Results	17
8. VOLTAGE FLUCTUATIONS & FLICKER TEST	18
8.1. Block Diagram of Test Setup	18
8.2. Test Standard	18
8.3. Operating Condition of EUT	18
8.4. Test Data	18
8.5. Test Results	18
9. ELECTROSTATIC DISCHARGE TEST	19
9.2. Test Standard	19
9.4. EUT Configuration on Test	19
9.5. Operating Condition of EUT	20
9.6. Test Procedure	20



9.7. Test Results 20
Electrostatic Discharge Test Results 21
10. RF FIELD STRENGTH SUSCEPTIBILITY TEST 22
10.1. R/S Test Setup 22
10.2. Test Standard 22
10.4. EUT Configuration on Test 23
10.5. Operating Condition of EUT 23
10.6. Test Procedure 23
10.7. Test Results 23
RF Field Strength Susceptibility Test Results 24
11. ELECTRICAL FAST TRANSIENT/BURST TEST 25
11.1. EFT Test Setup 25
11.2. Test Standard 25
11.4. EUT Configuration on Test 25
11.5. Operating Condition of EUT 25
11.6. Test Procedure 26
11.7. Test Results 26
Electrical Fast Transient/Burst Test Results 27
12. SURGE TEST 28
12.1. Surge Test Setup 28
12.2. Test Standard 28
12.4. EUT Configuration on Test 28
12.5. Operating Condition of EUT 28
12.6. Test Procedure 29
12.7. Test Results 29
Surge Immunity Test Results 30
13. INJECTED CURRENTS SUSCEPTIBILITY TEST 31
13.2. Test Standard 31
13.4. EUT Configuration on Test 31
13.5. Operating Condition of EUT 31
13.6. Test Procedure 32
13.7. Test Results 32
Injected Currents Susceptibility Test Results 33
14. VOLTAGE DIPS AND INTERRUPTIONS TEST 34
14.2. Test Standard 34
14.4. EUT Configuration on Test 34
14.5. Operating Condition of EUT 34
14.6. Test Procedure 35
14.7. Test Result 35
Voltage Dips And Interruptions Test Results 36
APPENDIX I 37
APPENDIX II 40
APPENDIX III 43



TEST REPORT DECLARATION

Applicant : Shenzhen Big Fish Sports Technology Co . , LTD.
Address : 1-17 Jiangnan Building ,No.21, East Yongxiang Road, Ma' an tang Community,Bantian Street,Longgang District, Shenzhen, China.

EUT Description : Electric Bicycle
Cavity Workbench Model Number : ENGINE X

Test Standards :
EN 15194: 2017

The EUT described above is tested by BST Testing (Shenzhen) Co.,Ltd. EMC Laboratory to determine the maximum emissions from the EUT and ensure the EUT to be compliance with the immunity requirements of the EUT. BST Testing (Shenzhen) Co.,Ltd. EMC Laboratory is assumed full responsibility for the accuracy of the test results. Also, this report shows that the EUT technically complies with the 2014/30/EU directive and its amendment requirements.

The test report is valid for above tested sample only and shall not be reproduced in part without written approval of the laboratory.

Prepared by :

Ivy Zhong

Assistant

Tested by :

Toby Zhong

Test Engineer

Reviewer :



Approved & Authorized Signer :

chen



1. TEST RESULTS SUMMARY

Table 1 Test Results Summary

Test Items	Test Results
Power Line Conducted Emission Test	PASS
Disturbance Power Test	PASS
Harmonic Current Emission Test	PASS
Voltage Fluctuations & Flicker Test	PASS
Electrostatic Discharge Test	PASS
RF Field Strength Susceptibility Test	PASS
Electrical Fast Transient/Burst Test	PASS
Surge Test	PASS
Injected Currents Susceptibility Test	PASS
Voltage Dips And Interruptions Test	PASS



2. GENERAL INFORMATION

2.1. Report information

- 2.1.1. This report is not a certificate of quality; it only applies to the sample of the specific product/equipment given at the time of its testing. The results are not used to indicate or imply that they are application to the similar items. In addition, such results must not be used to indicate or imply that BST approves recommends or endorses the manufacture, supplier or use of such product/equipment, or that BST in any way guarantees the later performance of the product/equipment.
- 2.1.2. The sample/s mentioned in this report is/are supplied by Applicant, BST therefore assumes no responsibility for the accuracy of information on the brand name, model number, origin of manufacture or any information supplied.
- 2.1.3. Additional copies of the report are available to the Applicant at an additional fee. No third part can obtain a copy of this report through BST, unless the applicant has authorized BST in writing to do so.

2.2. Measurement Uncertainty

(95% confidence levels, $k=2$)

Test Item	Uncertainty
Uncertainty for Conduction emission test	2.2dB
Uncertainty for Power disturbance Test	3.0dB



3. PRODUCT DESCRIPTION

3.1. EUT Description

Description : Electric Bicycle
Shenzhen Big Fish Sports Technology Co . , LTD.
Applicant : 201-17 Jiangnan Building ,No.21, East Yongxiang Road, Ma' an
tang Community,Bantian Street,Longgang District, Shenzhen,
CHINA
Manufacturer : SPACE CARDAN INDUSTRIES CO.,LTD
No.27 TIANREN INDUSTRY PARK LELIU SHUNDE FOSHAN CITY
GUANGDONG CHINA
Model Number : ENGINE X

3.2. Block Diagram of EUT Configuration

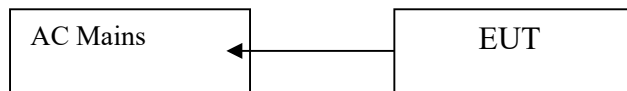

3.3. Operating Condition of EUT

Test mode 1: ON

3.4. Test Conditions

Temperature: 23-26°C
Relative Humidity: 55-68 %

3.5. Modifications

No modification was made.



3.6. Abbreviations

AC	Alternating Current
AMN	Artificial Mains Network
DC	Direct Current
EM	ElectroMagnetic
EMC	ElectroMagnetic Compatibility
EUT	Equipment Under Test
IF	Intermediate Frequency
RF	Radio Frequency
rms	root mean square
EMI	Electromagnetic Interference
EMS	Electromagnetic Susceptibility

3.7. Performance Criterion

Criterion A: The equipment shall continue to operate as intended without operator intervention. No degradation of performance or loss of function is allowed below a performance level specified by the manufacturer when the equipment is used as intended.

Criterion B: After the test, the equipment shall continue to operate as intended without operator intervention. No degradation of performance or loss of function is allowed, after the application of the phenomena below a performance level specified by the manufacturer, when the equipment is used as intended.

Criterion C: Loss of function is allowed, provided the function is self-recoverable, or can be restored by the operation of the controls by the user in accordance with the manufacturer's instructions.



4. TEST EQUIPMENT USED

4.1. For Conducted Emission Test

Item	Equipment	Manufacturer	Model No.	Serial No.	Last Cal.	Cal. Interval
1.	Test Receiver	Rohde & Schwarz	ESHS30	828985/018	Oct. 28, 21	1 Year
2.	Pulse Limiter	Rohde & Schwarz	ESH3-Z2	100006	Oct. 28, 21	1 Year
3.	L.I.S.N.	Rohde & Schwarz	ESH2-Z5	834549/005	Oct. 28, 21	1 Year
4.	Conical	Emtek	N/A	N/A	N/A	N/A
5.	Voltage Probe	Schwarzbeck	TK9416	N/A	Oct. 28, 21	1 Year
6.	Coaxial Electric bicycle	Anritsu	MP59B	6100214550	Oct. 28, 21	1 Year

4.2. For Disturbance Power Test

Item	Equipment	Manufacturer	Model No.	Serial No.	Last Cal.	Cal. Interval
1.	Test Receiver	Rohde & Schwarz	ESHS30	828985/018	Oct. 28, 21	1 Year
2.	Power Clamp	Rohde & Schwarz	MDS21	833711/025	Oct. 28, 21	1 Year
3.	Coaxial Electric bicycle	Anritsu	MP59B	6100214550	Oct. 28, 21	1 Year

4.3. For Harmonic / Flicker Test

Item	Equipment	Manufacturer	Model No.	Serial No.	Last Cal.	Cal. Interval
1.	Harmonic and Flicker analyzer	Laplace	AC2000A	309709	Oct. 28, 21	1 Year

4.4. For Electrostatic Discharge Immunity Test

Item	Equipment	Manufacturer	Model No.	Serial No.	Last Cal.	Cal. Interval
1.	ESD Tester	HAEFELY	PSD 1600	H911'292	Oct. 28, 21	1 Year

4.5. For RF Strength Susceptibility Test

Item	Equipment	Manufacturer	Model No.	Serial No.	Last Cal.	Cal. Interval
1.	Signal Generator	HP	8648A	3633A02081	Oct. 28, 21	1 Year
2.	Amplifier	A&R	500A100	17034	NCR	NCR
3.	Amplifier	A&R	100W/1000M1	17028	NCR	NCR
4.	Isotropic Field Monitor	A&R	FM2000	16829	NCR	NCR
5.	Isotropic Field Probe	A&R	FLW220100	16755	Oct. 28, 21	1 Year
6.	Biconic Antenna	EMCO	493E8	9507-2534	NCR	NCR
7.	Log-periodic Antenna	A&R	AT1080	16812	NCR	NCR
8.	PC	N/A	486DX2	N/A	N/A	N/A

4.6. For Electrical Fast Transient/Burst Immunity Test

Item	Equipment	Manufacturer	Model No.	Serial No.	Last Cal.	Cal. Interval
1.	Burst Tester	HAEFELY	PEFT 4010	080981-16	Oct. 28, 21	1 Year



4.7. For Surge Test

Item	Equipment	Manufacturer	Model No.	Serial No.	Last Cal.	Cal. Interval
1.	Surge Tester	HAEFELY	PSURGE4.1	080107-04	Oct. 28, 21	1 Year

4.8. For Injected Currents Susceptibility Test

Item	Equipment	Manufacturer	Model No.	Serial No.	Last Cal.	Cal. Interval
1.	Simulator	EMTEST	CWS 500C	0900-12	Oct. 28, 21	1 Year
2.	CDN	EMTEST	CDN-M2	510010010010	Oct. 28, 21	1 Year
3.	VDN	EMTEST	CDN-M3	0900-11	Oct. 28, 21	1 Year
4.	Injection Clamp	EMTEST	F-2031-23MM	368	Oct. 28, 21	1 Year
5.	Attenuator	EMTEST	ATT6	0010222a	Oct. 28, 21	1 Year

4.9. For Magnetic Field Immunity Test

Item	Equipment	Manufacturer	Model No.	Serial No.	Last Cal.	Cal. Interval
1.	Magnetic Field Tester	HEAFELY	MAG100.1	083858-10	Oct. 28, 21	1 Year

4.10. For Voltage Dips and Interruptions Test

Item	Equipment	Manufacturer	Model No.	Serial No.	Last Cal.	Cal. Interval
1.	Dips Tester	HEAFELY	PLINE 1610	083732-18	Oct. 28, 21	1 Year



5. POWER LINE CONDUCTED EMISSION TEST

5.1. Block Diagram of Test Setup

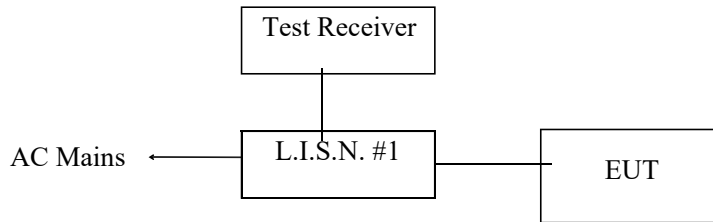

5.2. Test Standard

EN 15194:2017

5.3. Power Line Conducted Emission Limit

Frequency MHz	Limits dB(μV)	
	Quasi-peak Level	Average Level
0.15 ~ 0.50	66 ~ 56*	59 ~ 46*
0.50 ~ 5.00	56	46
5.00 ~ 30.00	60	50

Notes: 1. *Decreasing linearly with logarithm of frequency.
2. The lower limit shall apply at the transition frequencies.

5.4. EUT Configuration on Test

The following equipments are installed on conducted emission test to meet EN55014 requirement and operating in a manner, which tends to maximize its emission characteristics in a normal application.

5.4.1. EUT Information

Model Number : ENGINE X
Serial Number : N/A
Manufacturer : SPACE CARDAN INDUSTRIES CO.,LTD



5.5. Operating Condition of EUT

- 5.5.1. Setup the EUT and simulators as shown in Section 5.1.
- 5.5.2. Turn on the power of all equipments.
- 5.5.3. Let the EUT work in test modes (on) and test it.

5.6. Test Procedure

The EUT is put on the ground and connected to the AC mains through a Artificial Mains Network (AMN). This provided 50ohm-coupling impedance for the tested equipments. Both sides of AC line are checked to find out the maximum conducted emission levels according to the EN55014-1 regulations during conducted emission test.

The bandwidth of the test receiver is set at 9kHz.

The frequency range from 150 kHz to 30 MHz is investigated. and all the scanning waveform is put in **Appendix I**.

5.7. Test Result

PASS.

6. DISTURBANCE POWER TEST

6.1. Block Diagram of Test Setup

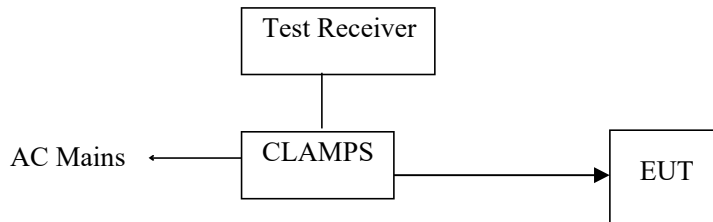

(EUT: Electric Bicycle)

6.2. Disturbance Power Limit

All emanations from devices or system, including any network of conductors and apparatus connected thereto, shall not exceed the level of field strengths specified below:

Frequency MHz	Interference Power Limits dB(pW)	
	Quasi-peak Value	Average Value
30 ~ 300	45 Increasing Linearly with Frequency to 55 (Q.P.)	35 Increasing Linearly with Frequency to 45 (A.V.)

6.3. EUT Configuration on Test

The EN55014 regulations test method must be used to find the maximum emission during radiated emission test.

The configuration of EUT is the same as used in conducted emission test. Please refer to Section 3.2

6.4. Operating Condition of EUT

Same as conducted emission test, which is listed in Section 5.1., except the test's setup replaced as Section 6.1.



6.5. Test Procedure

The EUT is placed on the ground and away from other metallic surface at least 0.4m. It is connected to the power mains through an extension cord of 6m min. The absorber clamp clamps the cord and moves from the far end to the EUT to measure the disturbing energy emitted from the cord.

The bandwidth of the test receiver is set at 120kHz.

All the test results are listed in Section 6.6.

The frequency spectrum from 30 MHz to 300 MHz is investigated.

As the peak value is too low against the limit, so the quasi-peak value and average value have omitted. All the scanning waveforms are attached in **Appendix II**.

6.6. Disturbance Power Test Result

PASS.



7. HARMONIC CURRENT EMISSION TEST

7.1. Block Diagram of Test Setup

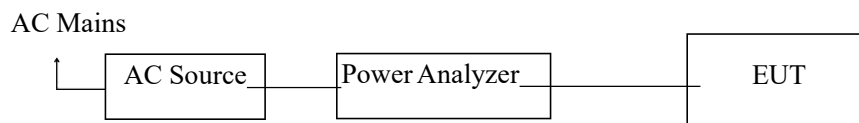

7.2. Test Standard and Limit

7.2.1. Test Standard

EN 15194: 2017

7.2.2. Limits

Table 12 Harmonic Current Test Limit (Class A)

Harmonic order (n)	Maximum permissible harmonic current (A)
Odd harmonics	
3	2.30
5	1.14
7	0.77
9	0.40
11	0.33
13	0.21
$15 \leq n \leq 39$	$0.15 \times 15/n$
Even harmonics	
2	1.08
4	0.43
6	0.30
$8 \leq n \leq 40$	$0.23 \times 8/n$



7.3. Test Procedure

The power cord of the EUT is connected to the output of the test system. Turn on the Power of the EUT and use the test system to test the harmonic current level.

7.4. Test Results

PASS.



8. VOLTAGE FLUCTUATIONS & FLICKER TEST

8.1. Block Diagram of Test Setup

Same as Section 7.1..

8.2. Test Standard

EN 15194: 2017

8.3. Operating Condition of EUT

Same as Section 7.3.. The power cord of the EUT is connected to the output of the test system. Turn on the power of the EUT and use the test system.

Flicker Test Limit

Test items	Limits
Pst	1.0
dc	3.3%
dmax	4.0%
dt	Not exceed 3.3% for 500ms

8.4. Test Data

Flicker test Data

Model No.: ENGINE X		
Test Mode: 1		
Items	Reading	Limit
dmax	0.04	4.0%
dc	0.02	3.3%
dt	0.05	Not exceed 3.3% for 500ms
Pst	0.001	1.0

8.5. Test Results

PASS

9. ELECTROSTATIC DISCHARGE TEST

9.1. Block Diagram of ESD Test Setup

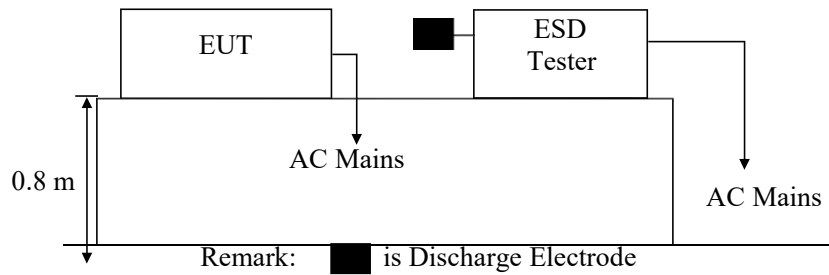

9.2. Test Standard

EN15194: 2017

Severity Level 3 for Air Discharge at 8KV

Severity Level 2 for Contact Discharge at 4KV

9.3. Severity Levels and Performance Criterion

9.3.1. Severity level

Level	Test Voltage Contact Discharge (KV)	Test Voltage Air Discharge (KV)
1.	2	2
2.	4	4
3.	6	8
4.	8	15
X.	Special	Special

9.3.2. Performance criterion: B

9.4. EUT Configuration on Test

The configuration of EUT are listed in Section 3.2.



9.5. Operating Condition of EUT

- 9.5.1. Set up the EUT as shown in Section 9.1..
- 9.5.2. Turn on the power of all equipments.
- 9.5.3. Let the EUT work in test mode (on) and test it.

9.6. Test Procedure

9.6.1. Air Discharge:

This test is done on a non-conductive surfaces. The round discharge tip of the discharge electrode shall be approached as fast as possible to touch the EUT. After each discharge, the discharge electrode shall be removed from the EUT. The generator is then re-triggered for a new single discharge and repeated 10 times for each pre-selected test point. This procedure shall be repeated until all the air discharge completed.

9.6.2. Contact Discharge:

All the procedure shall be same as Section 9.6.1. except that the tip of the discharge electrode shall touch the EUT before the discharge Electric Bicycle is operated.

9.6.3. Indirect discharge for horizontal coupling plane

At least 20 single discharges shall be applied to the horizontal coupling plane, at points on each side of the EUT. The discharge electrode positions vertically at a distance of 0.1m from the EUT and with the discharge electrode touching the coupling plane.

9.6.4. Indirect discharge for vertical coupling plane

At least 20 single discharge shall be applied to the center of one vertical edge of the coupling plane. The coupling plane, of dimensions 0.5m X 0.5m, is placed parallel to, and positioned at a distance of 0.1m from the EUT. Discharges shall be applied to the coupling plane, with this plane in sufficient different positions that the four faces of the EUT are completely illuminated.

9.7. Test Results

PASS

Please refer to the following page.



Electrostatic Discharge Test Results

BST Testing (Shenzhen) Co.,Ltd.

Discharge should be considered on Contact and Air and Horizontal Coupling Plane (HCP) and Vertical Coupling Plane (VCP).

<i>Applicant</i>	:	Shenzhen Big Fish Sports Technology Co . , LTD	<i>Test Date</i>	:	Jun .09, 2022
<i>EUT</i>	:	<i>Electric Bicycle</i>	<i>Temperature</i>	:	22°C
<i>M/N</i>	:	ENGINE X	<i>Humidity</i>	:	50 %
<i>Power Supply</i>	:	48V,13Ah/16Ah, 250W	<i>Test Mode</i>	:	on
<p><i>Air Discharge: ±8KV For each point positive 10 times and negative 10 times discharge.</i></p> <p><i>Contact Discharge: ±4KV</i></p>					
<i>Location</i>		<i>Kind</i> <i>A-Air Discharge</i> <i>C-Contact Discharge</i>		<i>Result</i>	
<i>Slots</i>		<i>A</i>		<i>PASS</i>	
<i>Metal Parts</i>		<i>C</i>		<i>PASS</i>	
<i>HCP</i>		<i>C</i>		<i>PASS</i>	
<i>VCP</i>		<i>C</i>		<i>PASS</i>	

10. RF FIELD STRENGTH SUSCEPTIBILITY TEST

10.1. R/S Test Setup

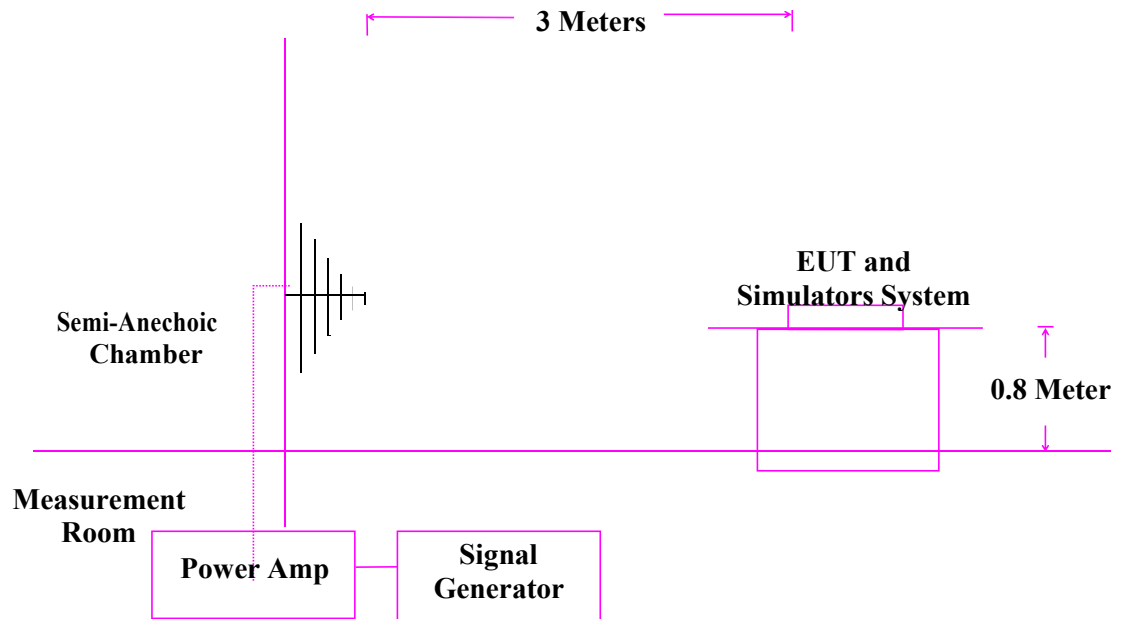

10.2. Test Standard

EN15194:2017
Severity Level 2 at 3V / m

10.3. Severity Levels and Performance Criterion

10.3.1. Severity level

Level	Field Strength V/m
1.	1
2.	3
3.	10
X.	Special

10.3.2. Performance criterion : A



10.4. EUT Configuration on Test

The configuration of EUT are listed in Section 3.2..

10.5. Operating Condition of EUT

Setup the EUT as shown in Section 10.1.. The operating condition of EUT are listed in section 3.3.

10.6. Test Procedure

The EUT and its simulators are placed on a turn table which is 0.8 meter above the ground. The EUT is set 3 meters away from the transmitting antenna which is mounted on an antenna tower. Both horizontal and vertical polarization of the antenna are set on test. Each of the four sides of EUT must be faced this transmitting antenna and measured individually.

In order to judge the EUT performance, a CCD camera is used to monitor the EUT. All the scanning conditions are as follows :

Condition of Test	Remarks
Fielded Strength	3 V/m (Severity Level 2)
Radiated Signal	Modulated
Scanning Frequency	80 - 1000 MHz, 1.4GHz-2.7GHz
Sweeping time of radiated	0.0015 decade/s
Dwell Time	1 Sec.

10.7. Test Results

PASS.

Please refer to the following page.



RF Field Strength Susceptibility Test Results

BST Testing (Shenzhen) Co.,Ltd.

<i>Applicant</i>	:	Shenzhen Big Fish Sports Technology Co . , LTD	<i>Test Date</i>	:	Jun .09, 2022
<i>EUT</i>	:	<i>Electric Bicycle</i>	<i>Temperature</i>	:	22°C
<i>M/N</i>	:	ENGINE X	<i>Humidity</i>	:	50 %
<i>Power Supply</i>	:	48V,13Ah/16Ah, 250W	<i>Test Mode</i>	:	on
<p><i>Test Engineer</i> <i>Frequency Range :</i> 80 MHz to 1000 MHz 1.4GHz-2.7GHz</p>					
<p><i>Modulation:</i> AM Pulse none 1 KHz 80%</p>					
<p><i>Criterion : A</i></p>					
		<p><i>Frequency Rang :</i> 80-1000MHZ, 1.4GHz-2.7GHz</p>			
<i>Steps</i>		1%			1%
		<i>Horizontal</i>			<i>Vertical</i>
<i>Front</i>		<i>Pass</i>			<i>Pass</i>
<i>Right</i>		<i>Pass</i>			<i>Pass</i>
<i>Rear</i>		<i>Pass</i>			<i>Pass</i>
<i>Left</i>		<i>Pass</i>			<i>Pass</i>

11. ELECTRICAL FAST TRANSIENT/BURST TEST

11.1. EFT Test Setup

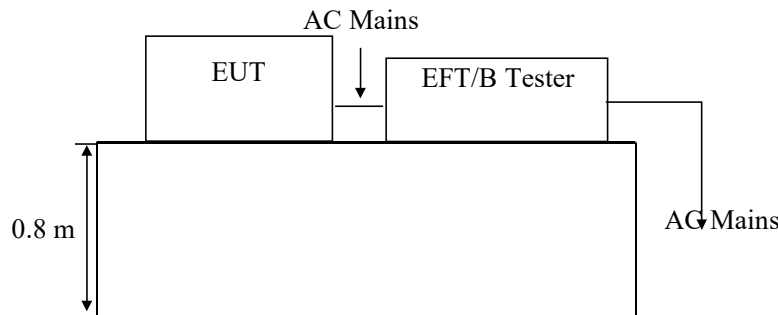

11.2. Test Standard

EN15194:2017
Severity Level 2 at 1KV

11.3. Severity Levels and Performance Criterion

11.3.1. Severity level

Open Circuit Output Test Voltage $\pm 10\%$		
Level	On Power Supply Lines	On I/O (Input/Output) Signal data and control lines
1.	0.5 KV	0.25 KV
2.	1 KV	0.5 KV
3.	2 KV	1 KV
4.	4 KV	2 KV
X	Special	Special

11.3.2. Performance criterion : B

11.4. EUT Configuration on Test

The configuration of EUT are listed in Section 3.2..

11.5. Operating Condition of EUT

Setup the EUT as shown in Section 11.1.. The operating condition of EUT are listed in section 3.3.



11.6. Test Procedure

The EUT is put on the table which is 0.8 meter high above the ground. This reference ground plane shall project beyond the EUT by at least 0.1m on all sides and the minimum distance between the EUT and all other conductive structure, except the ground plane beneath the EUT, shall be more than 0.5m.

11.6.1. For input and output AC power ports:

The EUT is connected to the power mains by using a coupling device which couples the EFT interference signal to AC power lines. Both polarities of the test voltage should be applied during compliance test and the duration of the test is 2 mins.

11.6.2. For signal lines and control lines ports:

It's unnecessary to test.

11.6.3. For DC output line ports:

It's unnecessary to test.

11.7. Test Results

PASS.

Please refer to the following page.



Electrical Fast Transient/Burst Test Results

BST Testing (Shenzhen) Co.,Ltd.

<i>Applicant</i>	:	Shenzhen Big Fish Sports Technology Co. , LTD	<i>Test Date</i>	:	Jun .09, 2022
<i>EUT</i>	:	Electric Bicycle	<i>Temperature</i>	:	22°C
<i>M/N</i>	:	ENGINE X	<i>Humidity</i>	:	50 %
<i>Power Supply</i>	:	48V,13Ah/16Ah, 250W	<i>Test Mode</i>	:	on
<i>Test Engineer</i>	:				

Inject Place : AC Mains

Inject Line	Voltage KV	Inject Time(s)	Inject Method	Results	Inject Line	Voltage KV	Inject Time(s)	Inject Method	Result s
L	±1	120	Direct	PASS					
N	±1	120	Direct	PASS					
L N	±1	120	Direct	PASS					

12. SURGE TEST

12.1. Surge Test Setup

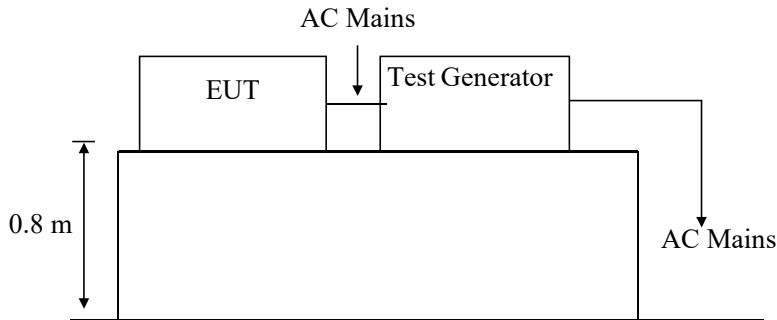

12.2. Test Standard

EN15194:2017
Severity Level 2 for Line to Neutral at 1.0KV

12.3. Severity Levels and Performance Criterion

12.3.1. Severity level

Severity Level	Open-Circuit Test Voltage KV
1	0.5
2	1.0
3	2.0
4	4.0
*	Special

Performance criterion : **B**

12.4. EUT Configuration on Test

The configuration of EUT are listed in Section 3.2..

12.5. Operating Condition of EUT

12.5.1. Setup the EUT as shown in Section 12.1..

12.5.2. Turn on the power of all equipments.

12.5.3. Let the EUT work in test mode (On) and test it.



12.6. Test Procedure

- 1) Set up the EUT and test generator as shown on Section 12.1
- 2) For line to line coupling mode, provide a 0.5KV 1.2/50us voltage surge (at open-circuit condition) and 8/20us current surge to EUT selected points.
- 3) At least 5 positive and 5 negative (polarity) tests with a maximum 1/min repetition rate are conducted during test.
- 4) Different phase angles are done individually.
- 5) Record the EUT operating situation during compliance test and decide the EUT immunity criterion for above each test.

12.7. Test Results

PASS.

Please refer to the following page.



Surge Immunity Test Results

BST Testing (Shenzhen) Co.,Ltd.

<i>Applicant</i>	:	Shenzhen Big Fish Sports Technology Co., LTD		<i>Test Date</i>	:	Jun .09, 2022
<i>EUT</i>	:	Electric Bicycle		<i>Temperature</i>	:	22°C
<i>M/N</i>	:	ENGINE X		<i>Humidity</i>	:	50 %
<i>Power Supply</i>	:	48V,13Ah/16Ah, 250W		<i>Test Mode</i>	:	on
<i>Test Engineer</i>	:					
<i>Location</i>		<i>Polarity</i>	<i>Phase Angle</i>	<i>No of Pulse</i>	<i>Pulse Voltage (KV)</i>	<i>Result</i>
L-N		+	0	5	1.0	PAS S
		+	90	5	1.0	PAS S
		+	180	5	1.0	PAS S
		+	270	5	1.0	PAS S
		-	0	5	1.0	PAS S
		-	90	5	1.0	PAS S
		-	180	5	1.0	PAS S
		-	270	5	1.0	PAS S

13. INJECTED CURRENTS SUSCEPTIBILITY TEST

13.1. Block Diagram of Test AC Mains Setup

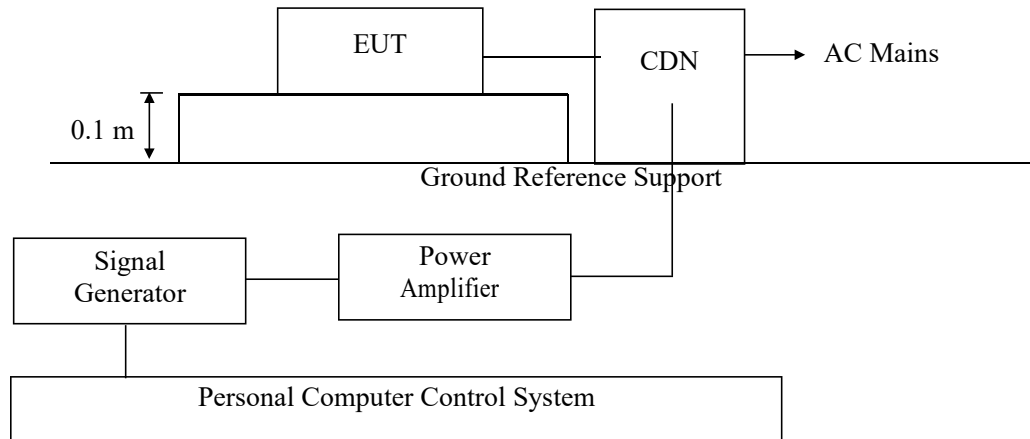

13.2. Test Standard

EN15194: 2017

Severity Level 2 at 3 V (rms), 0.15MHz ~ 80MHz

13.3. Severity Levels and Performance Criterion

13.3.1. Severity level

Level	Field Strength V/m
1.	1
2.	3
3.	10
X	Special

13.3.2. Performance criterion: A

13.4. EUT Configuration on Test

The configuration of EUT are listed in Section 3.2..

13.5. Operating Condition of EUT

Setup the EUT as shown in Section 13.1.. The operating condition of EUT are listed in section 3.3.



13.6. Test Procedure

- 1) Set up the EUT, CDN and test generators as shown on Section 13.1.
- 2) Let the EUT work in test mode and test it.
- 3) The EUT king is placed on an insulating support 0.8m high above a ground reference plane. CDN (coupling and decoupling device) is placed on the ground plane about 0.3m from EUT. Cables between CDN and EUT are as short as possible, and their height above the ground reference plane shall be between 30 and 50 mm (where possible).
- 4) The disturbance signal described below is transmitted to EUT through CDN.
- 5) The EUT operates within its operational mode(s) under intended climatic conditions after power on.
- 6) The frequency range is swept from 150KHz to 80MHz using 3V signal level, and with the disturbance signal 80% amplitude modulated with a 1KHz sine wave.
- 7) The rate of sweep shall not exceed 1.5×10^{-3} decades/s. Where the frequency is swept incrementally, the step size shall not exceed 1% of the start and thereafter 1% of the preceding frequency value.
- 8) Recording the EUT operating situation during compliance testing and define the EUT immunity criterion.

13.7. Test Results

PASS.

Please refer to the following page.



Injected Currents Susceptibility Test Results

BST Testing (Shenzhen) Co.,Ltd.

<i>Applicant</i>	:	<i>Shenzhen Big Fish Sports Technology Co . , LTD</i>	<i>Test Date</i>	:	<i>Jun .09, 2022</i>
<i>EUT</i>	:	<i>Electric Bicycle</i>	<i>Temperature</i>	:	<i>22°C</i>
<i>M/N</i>	:	<i>ENGINE X</i>	<i>Humidity</i>	:	<i>50 %</i>
<i>Power Supply</i>	:	<i>48V,13Ah/16Ah, 250W</i>	<i>Test Mode</i>	:	<i>on</i>
<i>Test Engineer</i>	:				
<i>Frequency Range (MHz)</i>		<i>Injected Position</i>	<i>Strength</i>	<i>Criterion</i>	<i>Result</i>
<i>0.15 ~ 20</i>		<i>AC Line</i>	<i>3V(rms), Unmodulate d</i>	<i>A</i>	<i>PASS</i>
<i>20 ~ 80</i>		<i>AC Line</i>	<i>3V(rms), Unmodulate d</i>	<i>A</i>	<i>PASS</i>

14. VOLTAGE DIPS AND INTERRUPTIONS TEST

14.1. Voltage Dips and Interruptions Test Setup

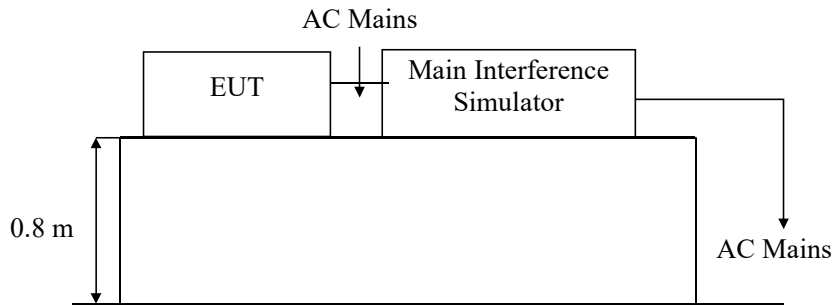

Remark: Combination wave generator and decoupling network are included in test generator.

14.2. Test Standard

EN15194:2017

14.3. Severity Levels and Performance Criterion

14.3.1. Severity level

Test Level %U _T	Voltage dip and short interruptions %U _T	Duration (in period)
0	100	0.5p
40	60	10p
70	30	25p

14.3.2. Performance criterion : C

14.4. EUT Configuration on Test

The configuration of EUT are listed in Section 3.2.

14.5. Operating Condition of EUT

14.5.1. Setup the EUT as shown in Section 14.1..

14.5.2. Turn on the power of all equipments.

14.5.3. Let the EUT work in test mode (On) and test it.



14.6. Test Procedure

- 1) Set up the EUT and test generator as shown on Section 14.1.
- 2) The interruptions is introduced at selected phase angles with specified duration.
- 3) Record any degradation of performance.

14.7. Test Result

PASS.

Please refer to the following page.



Voltage Dips And Interruptions Test Results

BST Testing (Shenzhen) Co.,Ltd.

<i>Applicant</i>	:	Shenzhen Big Fish Sports Technology Co . , LTD		<i>Test Date</i>	:	Jun .09, 2022
<i>EUT</i>	:	Electric Bicycle		<i>Temperature</i>	:	22°C
<i>M/N</i>	:	ENGINE X		<i>Humidity</i>	:	50%
<i>Power Supply</i>	:	48V,13Ah/16Ah, 250W		<i>Test Mode</i>	:	on
<i>Test Engineer</i>	:					
<i>Test Level</i> % U_T		<i>Voltage Dips & Short Interruptions</i> % U_T	<i>Duration</i> (in period)	<i>Phase Angle</i>	<i>Criterion</i>	<i>Result</i>
0		100	0.5p	$0 \sim 360^\circ$	C	PASS
40		60	10p	$0 \sim 360^\circ$	C	PASS
70		30	25p	$0 \sim 360^\circ$	C	PASS



APPENDIX I

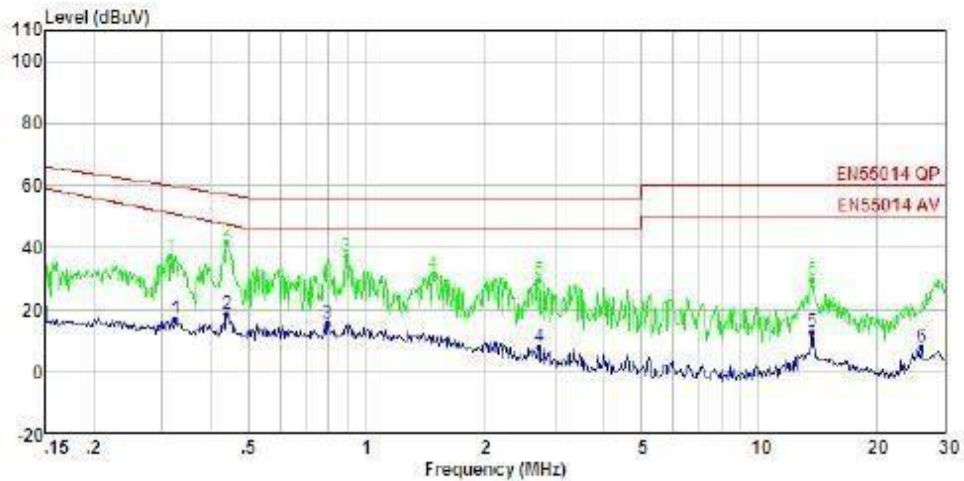

Site : Shenzhen BST Technology Co.,Ltd.

Condition:

: RBW:9.000KHz VBW:30.000KHz

	Freq	Level	Limit	Over	Remark	Pol/Phase
			Line	Limit		
	MHz	dBuV	dBuV	dB		
1	0.325	16.8	50.6	-33.8	Average	NEUTRAL
2 Max	0.440	18.5	47.4	-28.9	Average	NEUTRAL
3	0.798	15.5	46.0	-30.5	Average	NEUTRAL
4	2.738	7.9	46.0	-38.1	Average	NEUTRAL
5	13.695	12.5	50.0	-37.5	Average	NEUTRAL
6	26.139	7.7	50.0	-42.3	Average	NEUTRAL

Site : Shenzhen BST Technology Co.,Ltd.

Condition:

: RBW:9.000KHz VBW:30.000KHz

	Freq	Level	Limit	Over	Remark	Pol/Phase
			Line	Limit		
	MHz	dBuV	dBuV	dB		
1	0.317	37.0	50.8	-22.8	Peak	NEUTRAL
2 Max	0.440	41.8	51.1	-19.3	Peak	NEUTRAL
3	0.890	36.9	56.0	-19.1	Peak	NEUTRAL
4	1.480	31.2	56.0	-24.8	Peak	NEUTRAL
5	2.738	29.5	56.0	-26.5	Peak	NEUTRAL
6	13.695	29.5	60.0	-30.5	Peak	NEUTRAL

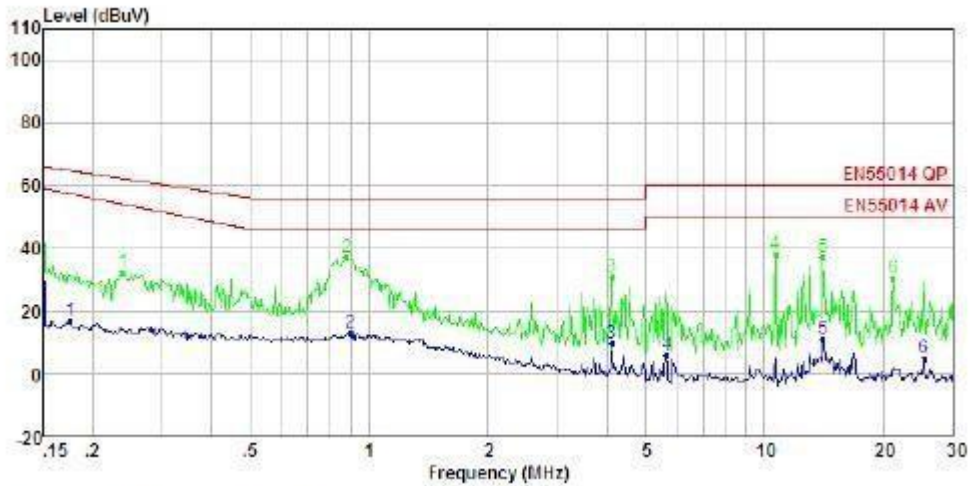

Site : Shenzhen BST Technology Co.,Ltd.

Condition:

: RBW:9.000KHz VBW:30.000KHz

	Freq	Level	Limit	Over	Remark	Pol/Phase
	MHz	dBuV	dBuV	dB		
1	0.176	17.0	57.9	-40.3	Average	LINE
2 Max	0.899	13.1	45.0	-32.0	Average	LINE
3	4.114	9.6	45.0	-35.4	Average	LINE
4	5.553	6.0	50.0	-44.0	Average	LINE
5	14.063	11.3	50.0	-38.7	Average	LINE
6	25.321	4.9	50.0	-45.1	Average	LINE

Site : Shenzhen BST Technology Co.,Ltd.

Condition:

: RBW:9.000KHz VBW:30.000KHz

	Freq	Level	Limit	Over	Remark	Pol/Phase
	MHz	dBuV	dBuV	dB		
1	0.239	32.1	62.1	-30.0	Peak	LINE
2 Max	0.660	37.2	55.0	-18.0	Peak	LINE
3	4.114	30.9	55.0	-25.1	Peak	LINE
4	10.878	37.9	60.0	-22.1	Peak	LINE
5	14.063	37.1	60.0	-22.9	Peak	LINE
6	21.147	30.2	60.0	-29.8	Peak	LINE



APPENDIX II

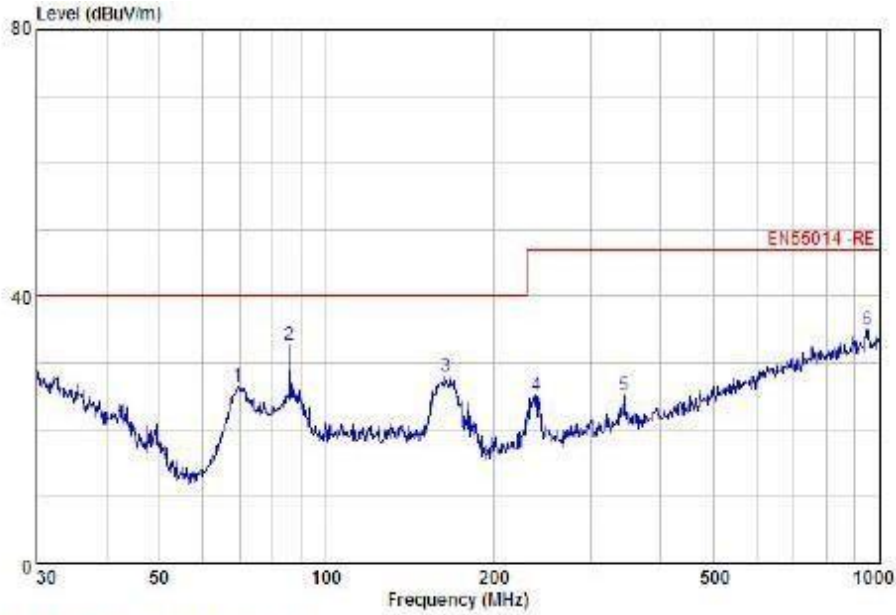

Condition : EN55014-RE 3m HORIZONTAL
 : RBW:120.000KHz VBW:300.000KHz SWT:Auto

	Freq	Level	Remark	Pol/Phase	Limit	Over
	MHz	dBuV/m			dBuV/m	dB
1	69.357	25.5	Peak	HORIZONTAL	40.0	-13.5
2	85.898	32.7	Peak	HORIZONTAL	40.0	-7.3
3	163.755	28.1	Peak	HORIZONTAL	40.0	-11.9
4	238.310	25.1	Peak	HORIZONTAL	47.0	-21.9
5	344.386	25.2	Peak	HORIZONTAL	47.0	-21.8
6	648.761	35.0	Peak	HORIZONTAL	47.0	-12.0

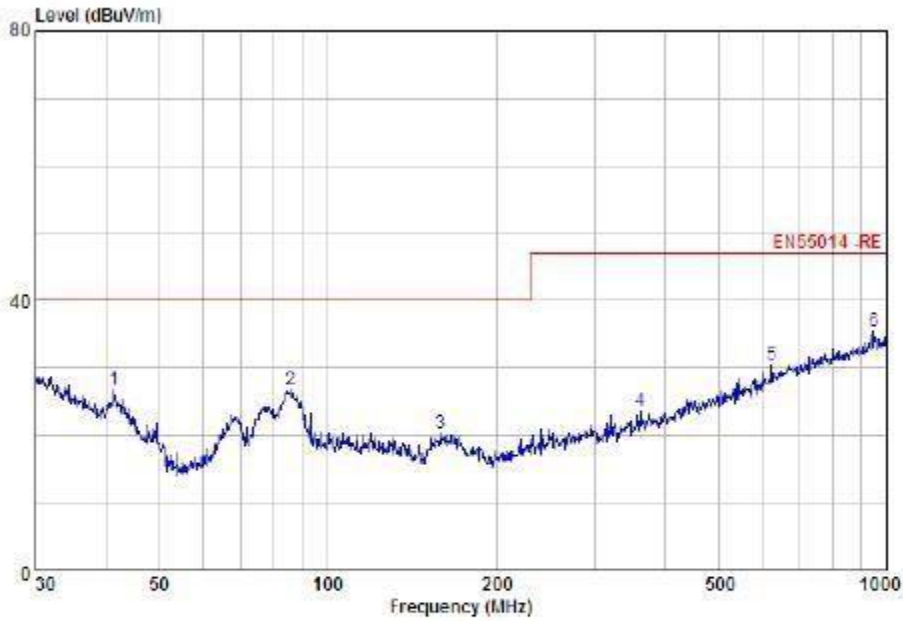

Condition : EN55014 -RE 3m VERTICAL
 : RBW:120.000kHz VBW:300.000kHz SWT:Auto

	Freq	Level	Remark	Pol/Phase	Limit	Over
	MHz	dBuV/m			dBuV/m	dB
1	41.422	28.8	Peak	VERTICAL	40.0	-13.2
2	85.898	28.7	Peak	VERTICAL	40.0	-13.3
3	159.325	20.2	Peak	VERTICAL	40.0	-19.8
4	361.714	28.8	Peak	VERTICAL	47.0	-23.4
5	622.890	30.4	Peak	VERTICAL	47.0	-16.6
6	948.761	35.4	Peak	VERTICAL	47.0	-11.6



APPENDIX III

Photo 1



Photo 2



Photo 3



Photo 4

